

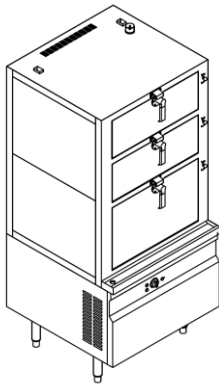

Total Food-Service Solutions

**Chinese Pro Modular Electric Steamer  
NESCD 9-90, Electric Steamer  
With 3 Chamber Decks**

ITEM# \_\_\_\_\_  
MODEL# \_\_\_\_\_  
NAME# \_\_\_\_\_  
S/N# \_\_\_\_\_



**Chinese Pro Modular Electric Steamer**

**Electric Steamer with 3 Chamber Decks**

NESCD 9-90      THREE CHAMBER DECKS  
ELECTRIC CONTROL KNOB

**Short Form Specification**

**Item No.**

Nayati Electric Steamer with 3 Chamber Decks is an excellent cooking appliance made of stainless steel with 27 kW power rate. It is completed with electronic 3 power levels. Top and exhaust are mounted by 1.2 mm of Stainless Steel and Side Panel is constructed of 1.0 mm of Stainless Steel.

**Main Features**

- Insulated water exchanger for efficiency.
- Water level detection and overheat heater protection

**Construction**

- All exterior panels in 304 type of Stainless Steel

**Included Accessories**

- Wire Grid 650x600 mm

**Optional Accessories**

- N/A.

APPROVAL: \_\_\_\_\_

Chinese Pro Modular Electric Steamer  
NESCD 9-90, Electric Steamer  
with 3 Chamber Decks

**Front**

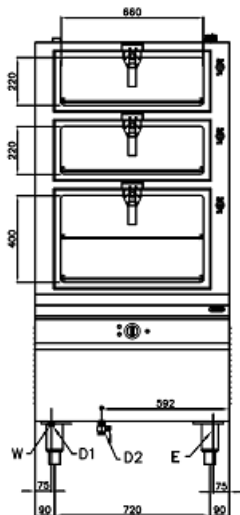

**Top**

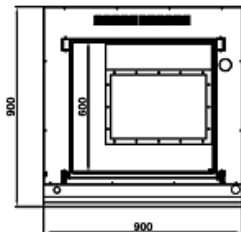

**Side**

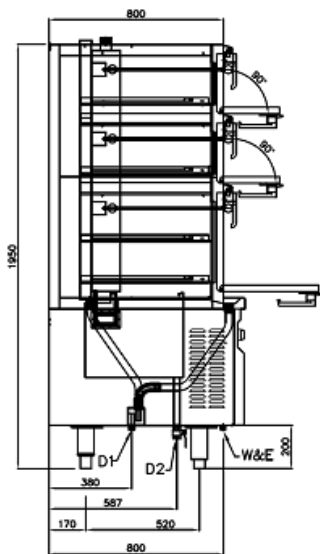

- (D) Drain Connection
- (W) Water Inlet
- (E) Electric Connection

\* Overall Dimension in mm

**Electric**

Electrical rating (kW):	27
Element rating (kW):	9 kW x 3
Electrical supply voltage:	400V 3N
Required electrical supply (amps):	41
Electrical current split (amps):	-

**Key Information:**

Cooking Surface:	655 X 560 mm
Direct heat emission:	3.20 kW
Latent heat emission:	2.40 kW
Steam emission:	3.52 kg / h
Working Temperature MIN:	-
Working Temperature MAX:	-
Water Connection:	1/2"
Drain Valve:	D1=3/4" D2=3/4"
Water Pressure:	2-4 bar
Max Pressure:	-
Pan Capacity:	-
Net Weight:	-
Shipping Height:	-
Shipping Width:	-
Shipping Depth:	-
Shipping Volume:	-